

豊富なバリエーションの小型スライドスイッチ

スライドスイッチ SLIDE SWITCHES

CL-SB

RoHS 指令対応 RoHS compliant



特長 FEATURES

- 豊富なバリエーション
(回路構成、操作方向、端子形状:Jリード、ガル・ウイング、スルーホールピン)
- 銀接点に加えて金接点も標準化
- ストロークは2mm
- 耐熱性樹脂使用によるリフロー実装対応
- ツイン接点構造採用
- Wide variety
(circuit composition, operating direction, terminal shape: J-hook, Gull wing, Through hole pins)
- Standardization of the silver contacts as well as gold contacts
- Stroke is 2mm
- Using heat-resistant resin to support reflow soldering mounting
- Adopted Twin-contacts mechanism

型式表示 PART NUMBER DESIGNATION

<p>CL - SB - 2 3 B - 0 2 T</p>	<p>シリーズ名 Series name</p> <hr/> <p>回路数 No. of poles</p> <p>1 : 1 回路 1 pole</p> <p>2 : 2 回路 2 poles</p> <p>接点数 No. of positions</p> <p>2 : 2 接点 2 positions</p> <p>3 : 3 接点 3 positions</p> <p>端子形状 Shape of terminal</p> <p>A : Jリード J-hook</p> <p>B : ガル・ウイング Gull wing</p> <p>C : スルーホールピン Through hole pins</p> <p>C1 : 操作部側1本端子 PC terminals with one on the operation side ※1 and others on the opposite side</p> <p>C4 : 横配置端子1列 Terminals aligned laterally on one side ※1</p> <p>※1: 特定の型式のみラインナップしておりますので、型式一覧表をご確認ください。 Please check the following LIST OF PART NUMBERS.</p>	<p>包装形態 Form of packaging</p> <p>T : テーピング T : Taping</p> <p>空欄 : バルク Blank : Bulk in plastic bag</p> <p>接点材料 Contact material</p> <p>1 : 銀 Silver</p> <p>2 : 金 Gold</p> <p>設定方向 Setting position</p> <p>0 : 上部設定型 Top setting</p> <p>1 : 側部設定型 Side setting</p>
---------------------------------------	---	--

内部構造図 INTERNAL STRUCTURE

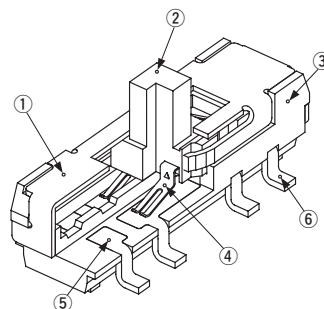

名称 Part name	材料 Material	燃焼性 Flammability
① カバー Cover	ステンレス Stainless steel (SUS 304)	—
② スライダ Slider	PA (ポリアミド) Polyamido	UL94V-0
③ ハウジング Housing	PPS (ポリフェニレンサルファイド) Polyphenylenesulphide	UL94V-0
④ 可動接点 Moving contact	銅合金、金 or 銀めっき Copper alloy, gold or silver plate	—
⑤ 固定接点 Fixed contact	銅合金、金 or 銀めっき Copper alloy, gold or silver plate	—
⑥ 端子 Terminal pin	銅合金、金 or 銀めっき Copper alloy, gold or silver plate	—

※ご注文に際しては、型式一覧表をご確認ください。

Please refer to the LIST OF PART NUMBERS when placing orders.

■型式一覧表 LIST OF PART NUMBERS

設定方向 Setting position	回路数 No. of poles	接点数 No. of positions	接点材料 Contact material		端子形状 Shape of terminal	包装形態 Form of packaging	包装数量 Pieces in package
			銀接点 Silver	金接点 Gold			
上部設定 Top setting	1	2	CL-SB-12A-01T	CL-SB-12A-02T	A(J-hook)	テーピング Taping	500pcs. / reel
			CL-SB-12A-01	CL-SB-12A-02		ポリ袋 Plastic bag	50pcs. / pack
			CL-SB-12B-01T	CL-SB-12B-02T	B(Gull wing)	テーピング Taping	500pcs. / reel
			CL-SB-12B-01	CL-SB-12B-02		ポリ袋 Plastic bag	50pcs. / pack
		CL-SB-12C-01	CL-SB-12C-02	C(Through hole pins)	ポリ袋 Plastic bag	50pcs. / pack	
		CL-SB-13A-01T	CL-SB-13A-02T	A(J-hook)	テーピング Taping	500pcs. / reel	
		CL-SB-13A-01	CL-SB-13A-02		ポリ袋 Plastic bag	50pcs. / pack	
		CL-SB-13B-01T	CL-SB-13B-02T	B(Gull wing)	テーピング Taping	500pcs. / reel	
		CL-SB-13B-01	CL-SB-13B-02		ポリ袋 Plastic bag	50pcs. / pack	
	CL-SB-13C-01	CL-SB-13C-02	C(Through hole pins)	ポリ袋 Plastic bag	50pcs. / pack		
	2	2	CL-SB-22A-01T	CL-SB-22A-02T	A(J-hook)	テーピング Taping	500pcs. / reel
			CL-SB-22A-01	CL-SB-22A-02		ポリ袋 Plastic bag	50pcs. / pack
			CL-SB-22B-01T	CL-SB-22B-02T	B(Gull wing)	テーピング Taping	500pcs. / reel
			CL-SB-22B-01	CL-SB-22B-02		ポリ袋 Plastic bag	50pcs. / pack
		CL-SB-22C-01	CL-SB-22C-02	C(Through hole pins)	ポリ袋 Plastic bag	50pcs. / pack	
		CL-SB-23A-01T	CL-SB-23A-02T	A(J-hook)	テーピング Taping	500pcs. / reel	
		CL-SB-23A-01	CL-SB-23A-02		ポリ袋 Plastic bag	50pcs. / pack	
		CL-SB-23B-01T	CL-SB-23B-02T	B(Gull wing)	テーピング Taping	500pcs. / reel	
CL-SB-23B-01		CL-SB-23B-02	ポリ袋 Plastic bag		50pcs. / pack		
CL-SB-23C-01	CL-SB-23C-02	C(Through hole pins)	ポリ袋 Plastic bag	50pcs. / pack			
側部設定 Side Setting	1	2	CL-SB-12A-11T	CL-SB-12A-12T	A(J-hook)	テーピング Taping	500pcs. / reel
			CL-SB-12A-11	CL-SB-12A-12		ポリ袋 Plastic bag	50pcs. / pack
			CL-SB-12B-11T	CL-SB-12B-12T	B(Gull wing)	テーピング Taping	500pcs. / reel
			CL-SB-12B-11	CL-SB-12B-12		ポリ袋 Plastic bag	50pcs. / pack
		CL-SB-12C-11	CL-SB-12C-12	C(Through hole pins)	ポリ袋 Plastic bag	50pcs. / pack	
		CL-SB-13A-11T	CL-SB-13A-12T	A(J-hook)	テーピング Taping	500pc s. / reel	
		CL-SB-13A-11	CL-SB-13A-12		ポリ袋 Plastic bag	50pcs. / pack	
		CL-SB-13B-11T	CL-SB-13B-12T	B(Gull wing)	テーピング Taping	500pcs. / reel	
		CL-SB-13B-11	CL-SB-13B-12		ポリ袋 Plastic bag	50pcs. / pack	
	CL-SB-13C-11	CL-SB-13C-12	C(Through hole pins)	ポリ袋 Plastic bag	50pcs. / pack		
	2	2	CL-SB-22A-11T	CL-SB-22A-12T	A(J-hook)	テーピング Taping	500pcs. / reel
			CL-SB-22A-11	CL-SB-22A-12		ポリ袋 Plastic bag	50pcs. / pack
			CL-SB-22B-11T	CL-SB-22B-12T	B(Gull wing)	テーピング Taping	500pcs. / reel
			CL-SB-22B-11	CL-SB-22B-12		ポリ袋 Plastic bag	50pcs. / pack
		CL-SB-22C-11	CL-SB-22C-12	C(Through hole pins)	ポリ袋 Plastic bag	50pcs. / pack	
		CL-SB-23A-11T	CL-SB-23A-12T	A(J-hook)	テーピング Taping	500pcs. / reel	
		CL-SB-23A-11	CL-SB-23A-12		ポリ袋 Plastic bag	50pcs. / pack	
		CL-SB-23B-11T	CL-SB-23B-12T	B(Gull wing)	テーピング Taping	500pcs. / reel	
		CL-SB-23B-11	CL-SB-23B-12		ポリ袋 Plastic bag	50pcs. / pack	
	CL-SB-23C-11	CL-SB-23C-12	C(Through hole pins)	ポリ袋 Plastic bag	50pcs. / pack		
	1	2	CL-SB-12C1-11	—	C1(Through hole pins)	ポリ袋 Plastic bag	50pcs. / pack
CL-SB-12C4-11			—	C4(Through hole pins)	ポリ袋 Plastic bag	50pcs. / pack	

※ご注文に際しては、上記型式をご確認ください。
テーピング仕様は、切り売り致しませんので、リール単位で
ご注文をお願い致します。

※Verify the above part numbers when placing orders.
Taping version can be supplied only in reel unit.

CL-SB

SLIDE SWITCHES

標準仕様

STANDARD SPECIFICATIONS

使用温度範囲 Operating temperature range	-40 ~ 85 °C
保存温度範囲 Storage temperature range	
シーリング性 Sealing	洗浄不可能 Non- Washable
質量 Net weight	0.21 g (CL-SB-12 ³ -0 [*]) 0.21 g (CL-SB-12 ³ -1 [*]) 0.22 g (CL-SB-22 ³ -0 [*]) 0.23 g (CL-SB-22 ³ -1 [*]) 0.26 g (CL-SB-13 ³ -0 [*]) 0.27 g (CL-SB-13 ³ -1 [*]) 0.28 g (CL-SB-23 ³ -0 [*]) 0.29 g (CL-SB-23 ³ -1 [*]) 0.21 g (CL-SB-12C1-11) 0.19 g (CL-SB-12C4-11)

機械的特性

MECHANICAL CHARACTERISTICS

ポジション数 No. of positions	2, 3
ストローク Stroke	2 mm
作動力 Operation force	2 接点 2 Contacts A ⇄ B ※ 1 (CL-SB-*2*-**) 1.5 ± 1.0 N {0.153 ± 0.102kgf} 3 接点 3 Contacts A→B / C→B ※ 2 (CL-SB-*3*-**) 1.5 ± 1.0 N {0.153 ± 0.102kgf} B→A / B→C 2.5 ± 1.5 N {0.255 ± 0.153kgf}
操作部の強度 Stop strength	20 N {2.04 kgf} 15 s
はんだ付け性 Solderability	245 ± 3 °C, 2 ~ 3 s
はんだ耐熱性 Soldering heat	リフロー Reflow : 255 °C (Peak temperature) (詳細は下記プロフィール参照 Please refer to the profile below)
	フロー Flow : 260 ± 3 °C, 5 ~ 6 s
	手はんだ Manual soldering : 350 ± 10 °C, 3 ~ 4 s
固着性 Shear	5 N {0.51 kgf} 10 s
耐基板曲げ性 Substrate bending	Width 90 mm, bend 3 mm, 5 s, 1 time
引きはがし強さ Pull-off strength	5 N {0.51 kgf} 10s

{ } : 参考値 Reference only

※ 1

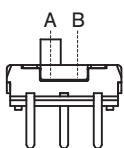

※ 2

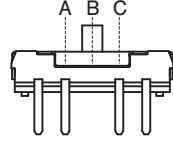

電気的特性

ELECTRICAL CHARACTERISTICS

接点定格 Contact rating	Non-switching DC50 V 200 mA Switching DC12 V 200 mA Minimum DC20 mV 1 μA (金接点 Gold contacts) DC5 V 10 mA (銀接点 Silver contacts)	
接点タイミング Contact timing	ノンショーティング Non-shorting	
接触抵抗 Contact resistance	70mΩ maximum (金接点 Gold contacts) 50mΩ maximum (銀接点 Silver contacts)	1.5 mA 1 kHz 20 mV maximum
絶縁抵抗 Insulation resistance	100 MΩ minimum (DC500 V)	
耐電圧 Dielectric strength	AC500 V, 60 s	

環境特性

ENVIRONMENTAL CHARACTERISTICS

耐振性 Vibration	振幅 (Amplitude) 1.5 mm (全振幅) or 加速度 (Acceleration) 98 m/s ² , 10-500-10 Hz, 3 directions for 2 h each
耐衝撃性 Shock	490 m/s ² , 11 ms 6 directions for 3 times each
耐久性 Load life	10000 cycles, サイクル DC12 ± 0.5V, 200 ± 10mA
耐湿性 Humidity	40 °C, 相対湿度 Relative humidity 90 ~ 95 %, 240 h, 無負荷 No load
耐熱性 High temperature exposure	85 °C, 96 h, 無負荷 No load
耐寒性 Low temperature exposure	-40 °C, 96 h, 無負荷 No load
温度サイクル Thermal shock	-40 (0.5 h) - 85 °C (0.5 h), 5 cycles

〈はんだ耐熱性評価用リフロープロフィール〉 Reflow profile for soldering heat evaluation

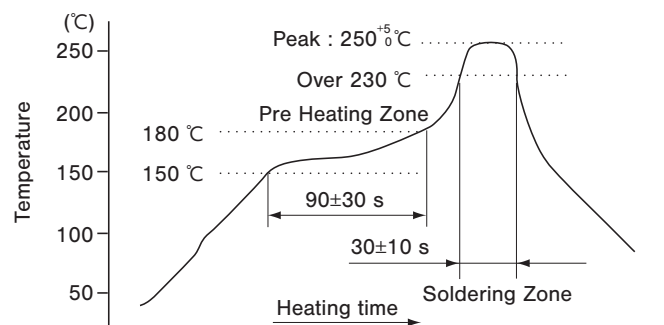

リフロー回数:2回 Reflow : two times maximum

CL-SB SLIDE SWITCHES

外形寸法図 OUTLINE DIMENSIONS

Unless otherwise specified, tolerance: ± 0.3 (Unit: mm)

- CL-SB-12A-01
- CL-SB-12A-02

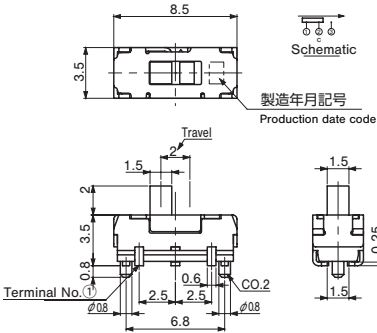

- CL-SB-12B-01
- CL-SB-12B-02

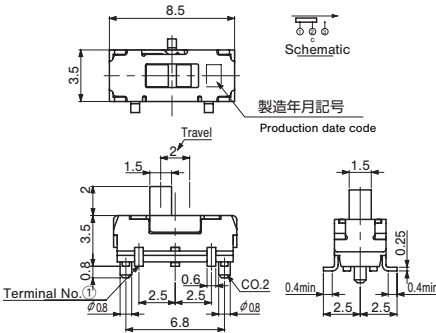

- CL-SB-12C-01
- CL-SB-12C-02

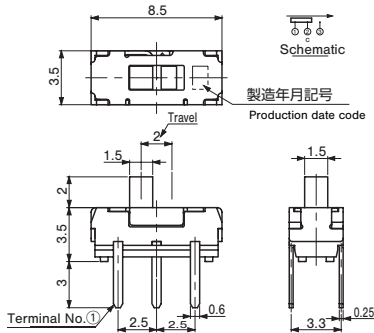

- CL-SB-12A-11
- CL-SB-12A-12

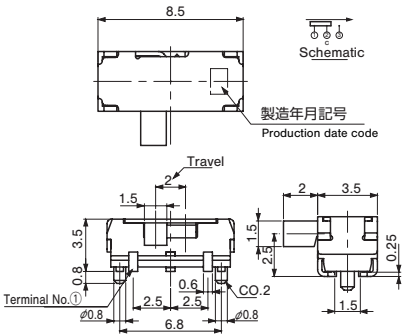

- CL-SB-12B-11
- CL-SB-12B-12

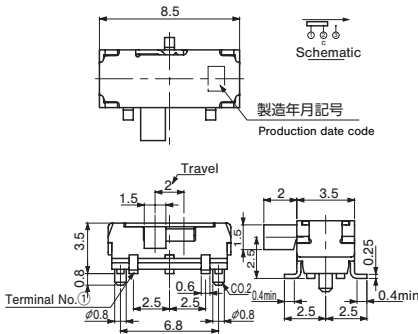

- CL-SB-12C-11
- CL-SB-12C-12

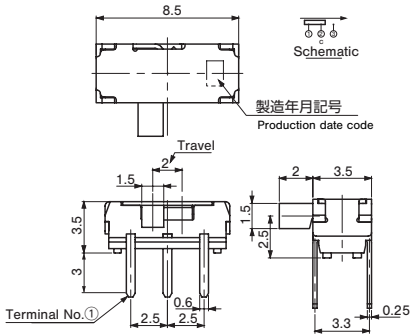

- CL-SB-22A-01
- CL-SB-22A-02

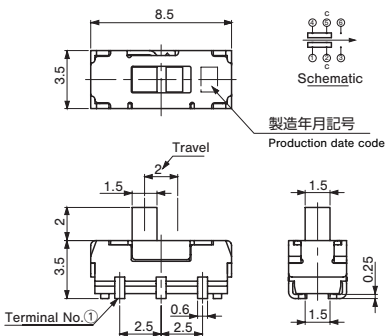

- CL-SB-22B-01
- CL-SB-22B-02

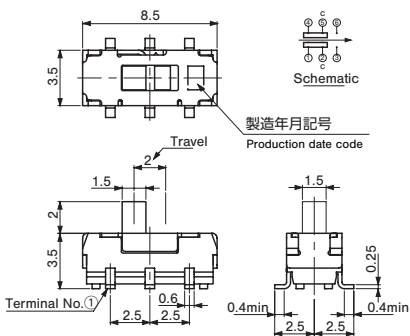

- CL-SB-22C-01
- CL-SB-22C-02

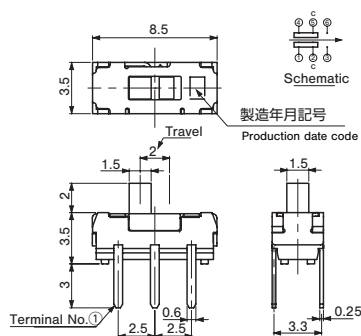

CL-SB SLIDE SWITCHES

外形寸法图 OUTLINE DIMENSIONS

Unless otherwise specified, tolerance: ± 0.3 (Unit: mm)

- CL-SB-22A-11
- CL-SB-22A-12

- CL-SB-22B-11
- CL-SB-22B-12

- CL-SB-22C-11
- CL-SB-22C-12

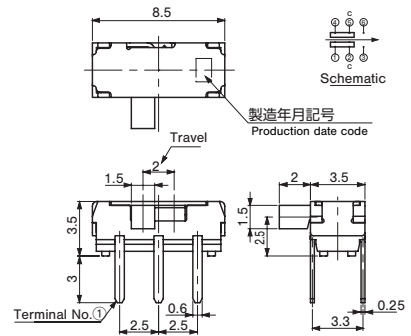
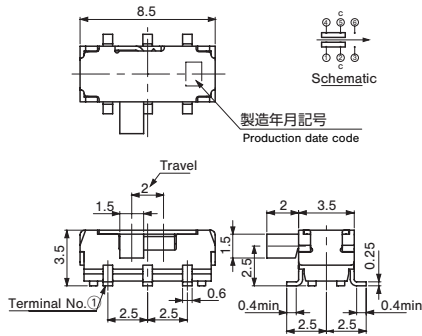
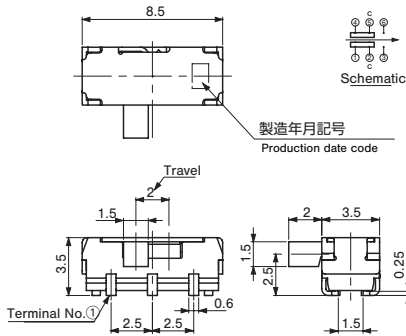

- CL-SB-13A-01
- CL-SB-13A-02

- CL-SB-13B-01
- CL-SB-13B-02

- CL-SB-13C-01
- CL-SB-13C-02

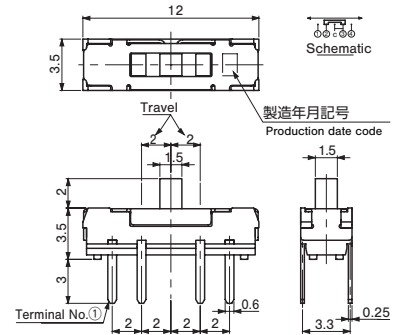
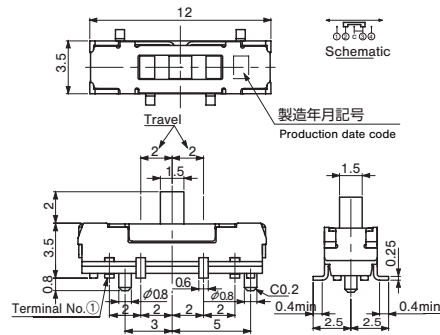
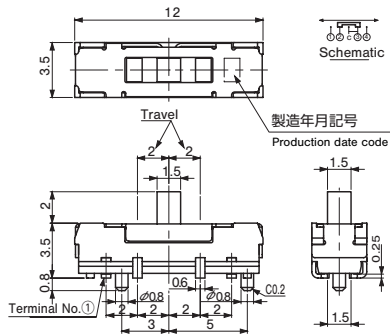

- CL-SB-13A-11
- CL-SB-13A-12

- CL-SB-13B-11
- CL-SB-13B-12

- CL-SB-13C-11
- CL-SB-13C-12

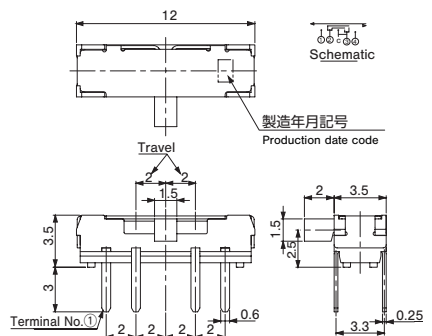
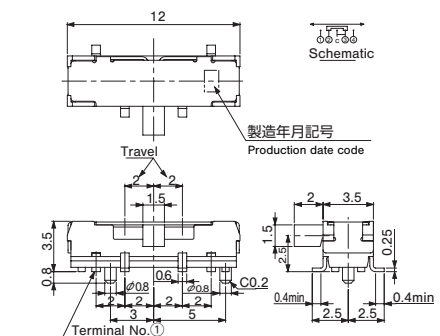
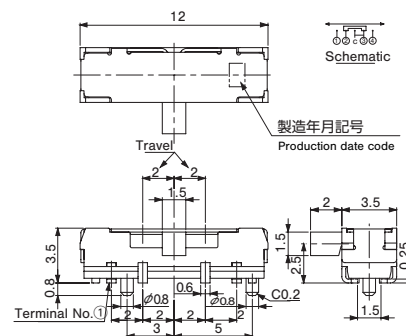

CL-SB SLIDE SWITCHES

- CL-SB-23A-01
- CL-SB-23A-02

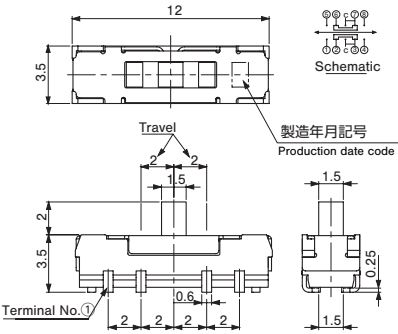

- CL-SB-23B-01
- CL-SB-23B-02

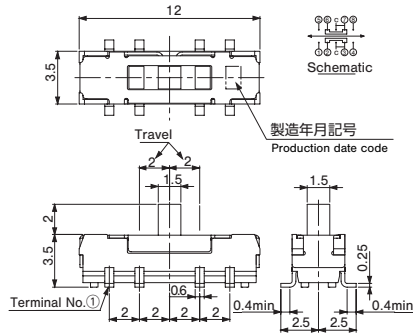

- CL-SB-23C-01
- CL-SB-23C-02

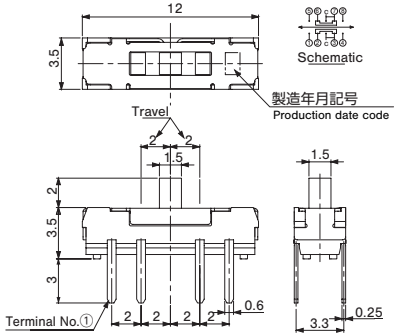

- CL-SB-23A-11
- CL-SB-23A-12

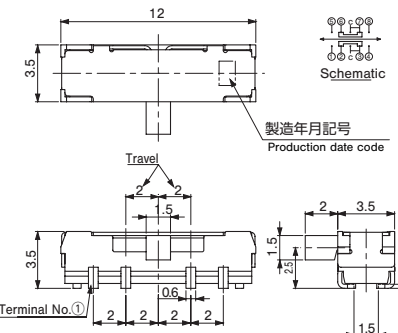

- CL-SB-23B-11
- CL-SB-23B-12

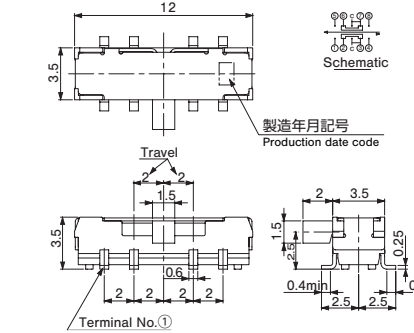

- CL-SB-23C-11
- CL-SB-23C-12

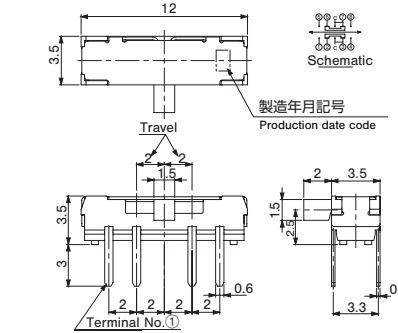

- CL-SB-12C1-11

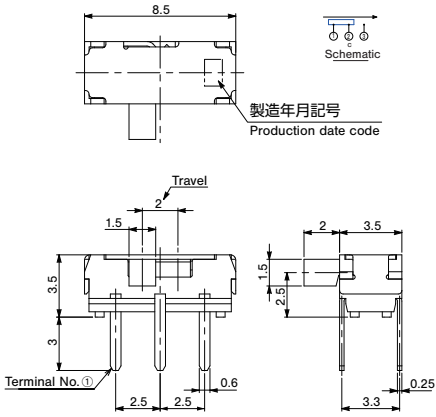

- CL-SB-12C4-11

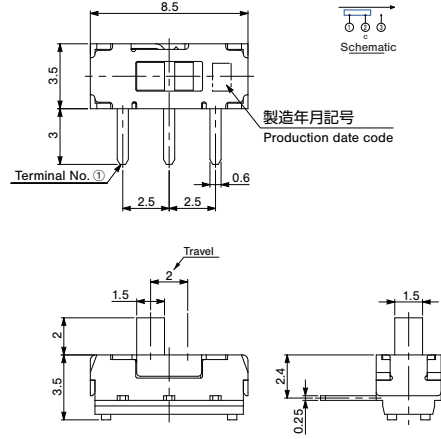

CL-SB SLIDE SWITCHES

推奨ランドパターン RECOMMENDED P.C.B. PAD OUTLINE DIMENSIONS

(Unit:mm)

● CL-SB-12A-□□

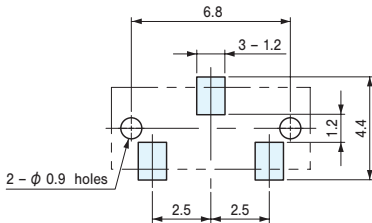

● CL-SB-12B-□□

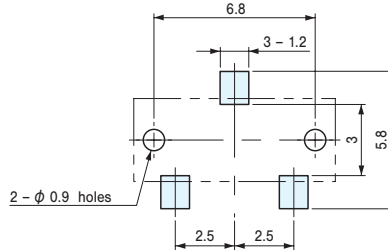

● CL-SB-22A-□□

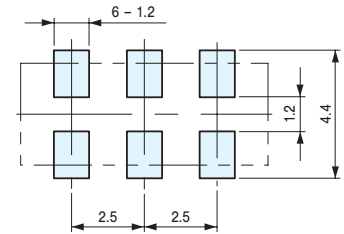

● CL-SB-22B-□□

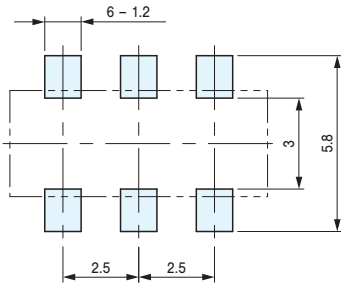

● CL-SB-13A-□□

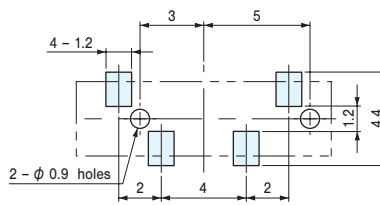

● CL-SB-13B-□□

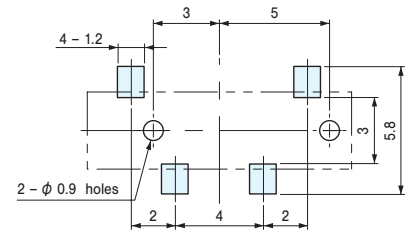

● CL-SB-23A-□□

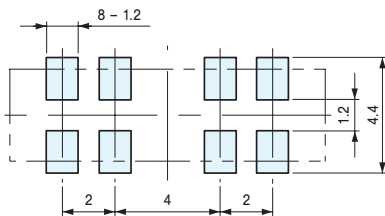

● CL-SB-23B-□□

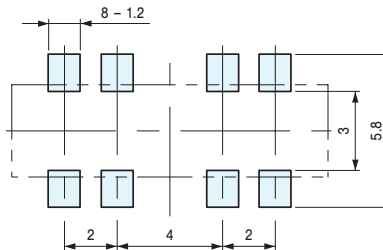

プリント基板加工寸法 SIZE OF P.C.B. PROCESSING

(Unit: mm)

● CL-SB-12C-□□

● CL-SB-12C1-11

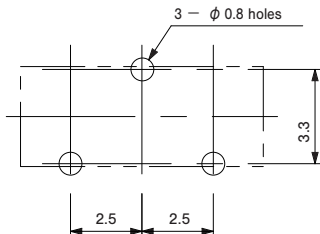

● CL-SB-13C-□□

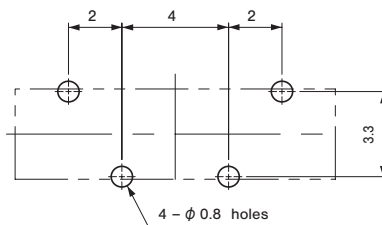

● CL-SB-22C-□□

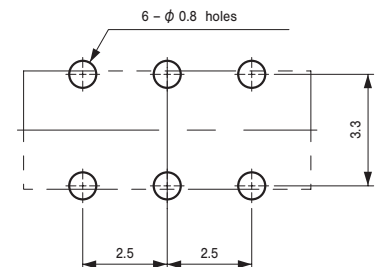

● CL-SB-23C-□□

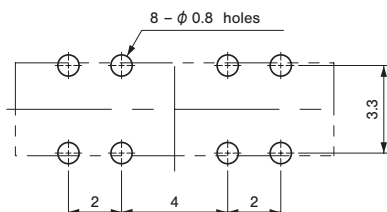

● CL-SB-12C4-11

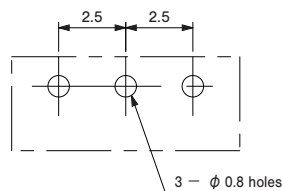

■ 包装仕様

〈ポリ袋の包装仕様〉

- ポリ袋での最小包装は、10個 / 袋となりますので、10個単位（10個、20個、30個、…）でのご注文をお願い致します。
- ポリ袋の箱詰めは、50個以上（通常は100個）を製品箱に包装致します。

〈テーピングの包装仕様〉

- テーピングは500個 / リール単位の包装になりますので、500個単位（500個、1000個、1500個…）でのご注文をお願い致します。
- テーピングリールの箱詰めは、1リール（500個）ごとに製品箱に包装致します。

製品の脱落は、連続2個以内と致します。

テープのリーダ部、空部およびリール寸法は図に示します。

● テープのリーダ部および空部 Embossed tape dimensions

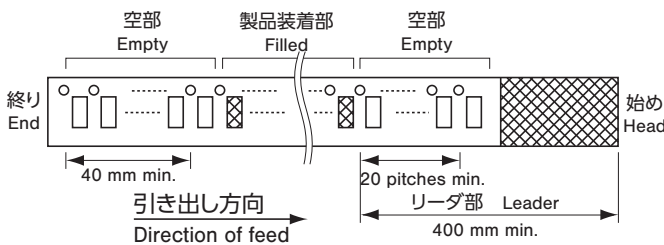

〈テープ寸法図 Tape dimensions〉

● CL-SB-12A/12B-0□T

(JIS C 0806 に一致 Conforms to JIS C 0806)

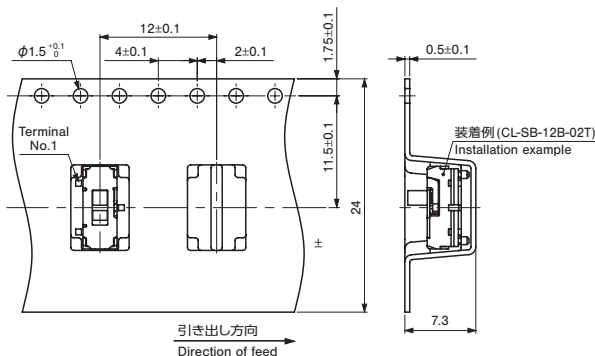

■ PACKAGING SPECIFICATIONS

〈Bulk pack specifications〉

- The smallest unit of bulk pack in plastic bag is 10 pcs. per pack. Orders will be accepted for unit of minimum 10 pcs., i.e., 10, 20, 30 pcs., etc.
- Boxing of bulk in a plastic bag is performed with 50 pcs. per box.

〈Taping packaging specifications〉

- Taping version is packaged in 500 pcs. per reel. Orders will be accepted for units of 500 pcs., i.e., 500, 1000, 1500, pcs., etc.
- Taping version is boxed with one reel (500 pcs.).

Maximum number of consecutive missing pieces=2
Leader length and reel dimension are shown in the diagrams below:

● リールの寸法図 Reel dimensions (Unit: mm)

(JIS C 0806-3 に一致 Conforms to JIS C 0806-3)

(EIAJ ET-7200A に準拠 In accordance with EIAJ ET-7200A)

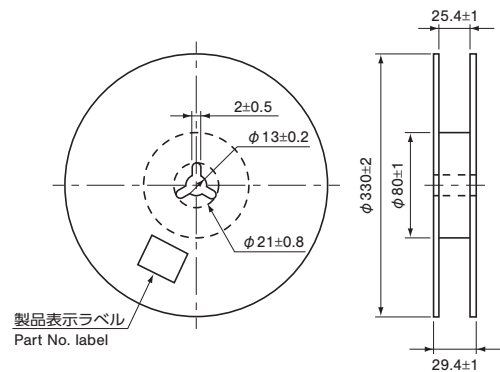

Unless otherwise specified, tolerance: ± 0.3 (Unit: mm)

● CL-SB-22A/22B-0□T

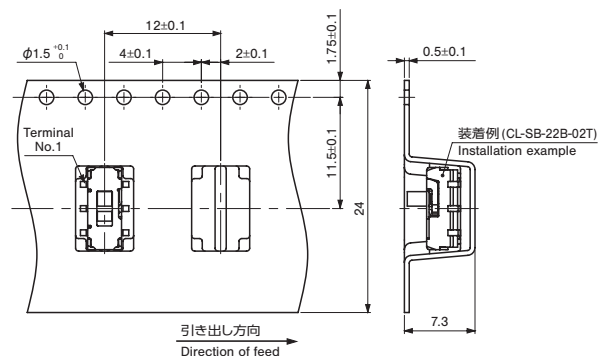

CL-SB SLIDE SWITCHES

〈テープ寸法図 Tape dimensions〉

Unless otherwise specified, tolerance: ± 0.3 (Unit: mm)

● CL-SB-13A/13B-0□T

● CL-SB-23A/23B-0□T

(JIS C 0806 に一致 Conforms to JIS C 0806)

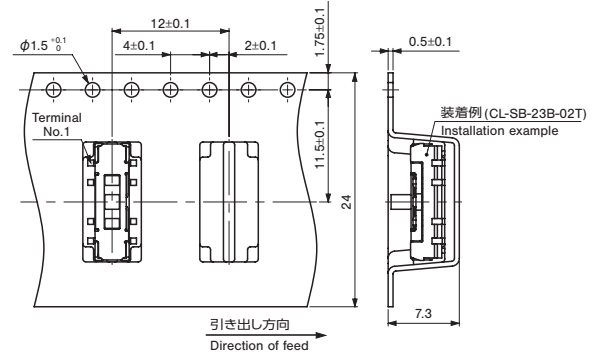
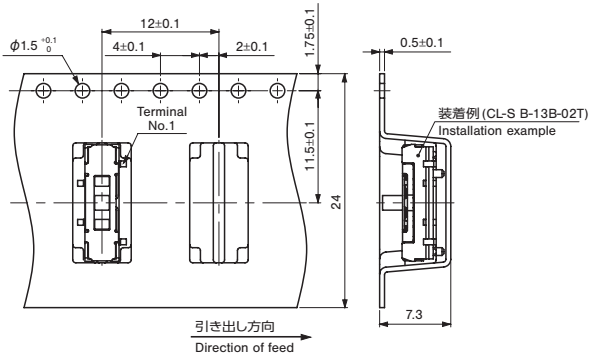

● CL-SB-12A/12B-1□T

● CL-SB-22A/22B-1□T

(JIS C 0806 に一致 Conforms to JIS C 0806)

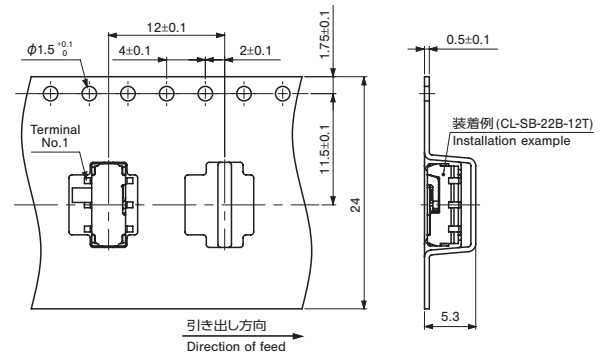
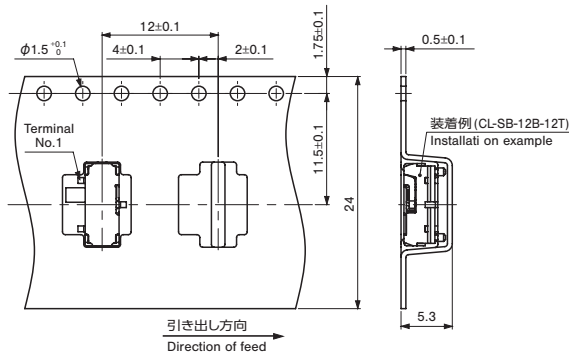

● CL-SB-13A/13B-1□T

● CL-SB-23A/23B-1□T

(JIS C 0806 に一致 Conforms to JIS C 0806)

