

250P/R、256P/R だからラクラク設定

設定用磁気式エンコーダ

MANUAL SETTING TYPE MAGNETIC ENCODERS

RMS20

■特長 FEATURES

- 256 P/R の高分解能で微細設定が可能
- 磁気式により省電力、15 mA maximum
- 無接触、磁気式により長寿命 (10⁵ 連続回転)
- 矩形波出力 (アンプ内蔵)
- 設定し易い回転フィーリング
- RoHS 指令対応
- High resolution of 256 P/R and fine setting
- Lower consumption of electric power (15 mA maximum) due to magnetic method
- Long life for 10⁵ times continuous run due to contactless & magnetic method
- Square wave output (with Amp.)
- Smooth rotation for setting
- RoHS compliant

RoHS 指令対応
RoHS compliant

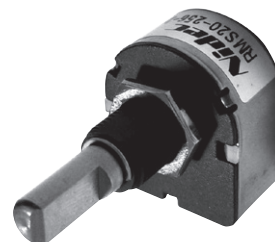

■型式表示 PART NUMBER DESIGNATION

RMS20 - 250 - 201 - 1

シリーズ名 Series name

分解能 Resolution (P/R)
100, 250, 256

出力端子 Output connection
1 : ケーブル出力 Cable wire

出力相 Output phase
2 : "A" & "B"

■型式一覧表 LIST OF PART NUMBERS

分解能 Resolution	項目 Item	電源電圧 Input voltage	型式 Part number
100 (P/R)		5 V	RMS20-100-201-1
250 (P/R)			RMS20-250-201-1
256 (P/R)			RMS20-256-201-1

※ご注文に際しては、上記型式をご確認ください。
Verify the above part numbers when placing orders.

■標準仕様 STANDARD SPECIFICATIONS

●電気的特性 Electrical characteristics

電源電圧 Input voltage	DC5 V ± 5 %		
電源電流 Input current	15 mA maximum (No load)		
出力波形 Output wave form	矩形波 Square wave		
出力相 Output phases	A, B		
分解能 (P/R) Resolution	100	250	256
A、B 位相差 Phase difference of outputs A & B	90° ± 45°		
最大応答周波数 Maximum frequency response	5 kHz		
出力信号 Output signal	"1 (High)"	+ 4.5 V minimum	
	"0 (Low)"	+ 0.5 V maximum	
検出部 Sensor	磁気抵抗素子 Magnetoresistive element		

●機械的特性 Mechanical characteristics

回転トルク Rotational torque	4.90 mN·m [50 gf·cm] maximum	
慣性モーメント Inertia	3 g·cm ² maximum	
シャフト荷重 (取付時) Shaft loading (When mounting)	ラジアル方向 Radial	9.81 N [1 kgf] maximum
	スラスト方向 Axial	9.81 N [1 kgf] maximum
機械的回転寿命 Rotational life	10 ⁵ 回転 revolution	
質量 Net weight	Approx. 20 g	
ネジ締め強度 Strength of tighten screw	0.49 N·m [5 kgf·cm] maximum	

●環境特性 Environmental characteristics

使用温度範囲 Operating temp. range	- 10 ~ 60 °C
保存温度範囲 Storage temp. range	- 40 ~ 70 °C
保護構造 Protection grade	IP40

■信頼性試験 RELIABILITY TEST

下記試験条件にて試験後、出力波形が下記規定仕様を満足する事。
 The output shall satisfy the criteria below after the following tests.

項目 Test item		試験条件 Test conditions
振動 Vibration	無通電 Power OFF	振幅 1.52 mm 又は 98.1 m/s ² (10 G) のいずれか小さい振幅 10 ~ 500 Hz 往復 15 min X、Y、Z 各 8 往復 Amplitude : 1.52 mm or 98.1 m/s ² (10 G) whichever is smaller. 10 ~ 500 Hz excursion 15 min/cycle, 8 cycles each for X, Y, Z, directions.
衝撃 Shock	無通電 Power OFF	490 m/s ² (50 G) 11 ms X、Z 方向 各 3 回 3 times each in directions (X, Z) at 490 m/s ² (50 G), 11 ms.
耐熱性 High temperature exposure	無通電 Power OFF	70 °C 96 h
	通電 Power ON	60 °C 96 h
耐寒性 Low temperature exposure	無通電 Power OFF	- 40 °C 96 h
耐湿性 Humidity	無通電 Power OFF	40°C 相対湿度 Relative humidity 90 ~ 95 % 96 h (試験後、水滴を除去し常温常湿に1時間放置後測定) (To be measured after wiping out moisture and leaving samples for 1 h at normal temperature and humidity after the test.)
熱衝撃 Thermal shock	無通電 Power OFF	下記条件にて 10 サイクル試験 (試験後、常温常湿に1時間放置後測定) To be done 10 cycles with the following condition (To be measured after leaving samples for 1 h at normal temperature and humidity after the test.) 70 °C 0.5 h、- 40 °C 0.5 h

■外形寸法図 OUTLINE DIMENSIONS

Unless otherwise specified, tolerance: ± 0.4 (Unit: mm)

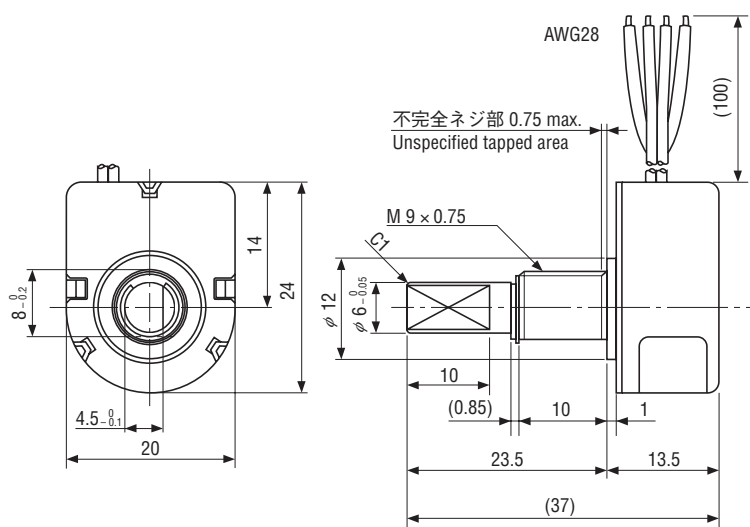

〈付属品 Accessories〉

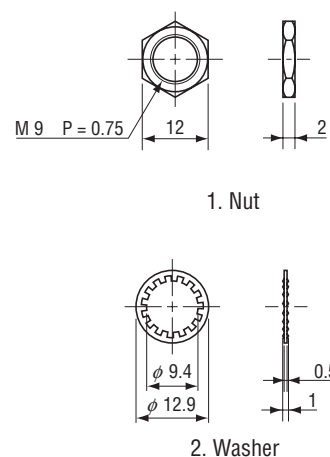

RMS20

MAGNETIC ENCODERS

出力 OUTPUT

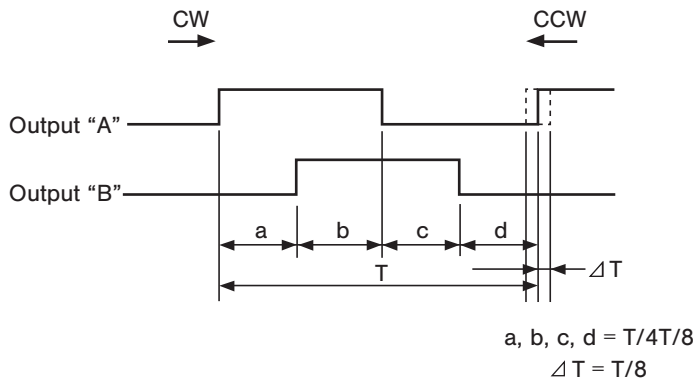

ケーブル配線 ELECTRICAL WIRING

Red	Power ⊕
Brown	Output "B"
White	Output "A"
Black	Power 0 (V)

出力回路 OUTPUT CIRCUIT

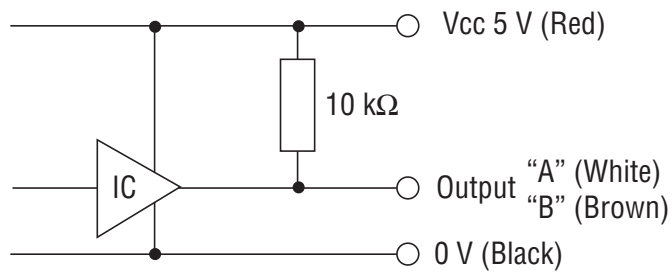

シンク電流は1 mA maximum (at 25 °C)
 Sink current 1 mA maximum (at 25 °C)