

**特長**

M5 から M16 まで豊富なねじサイズ、カラーバリエーションとデザイン。

**用途**

工作機械・治工具・各種試験機・計測機器等

**仕様**

カラーは他にツヤ消し黒色、オレンジ色もございます。又ステンレス製ねじのものもございます。

**Characteristic**

Choose one from wide variety of screw sizes from M5 to M16, color, and design.

**Application**

Machine tools / Jigs and tools / Various types of testing devices / Measuring instruments, etc.

**Specification**

Available with flat black color or orange color. Also, available with stainless steel screw.

**■部品表 Parts List**

部番 No.	部品名 Part Name	材質 Material	処理 Finish	数 Quantity
1	レバー Lever	ZDC	粉体塗装(シルバーグレー) Powder Coating (Silver Gray)	1
2	スリーブ Sleeve	SUM22L	四三酸化被膜(黒) Black Oxide	1
3	止めネジ Setscrew			1
4	スプリング Spring	SWPB	—	1

**THA-LDMタイプ**

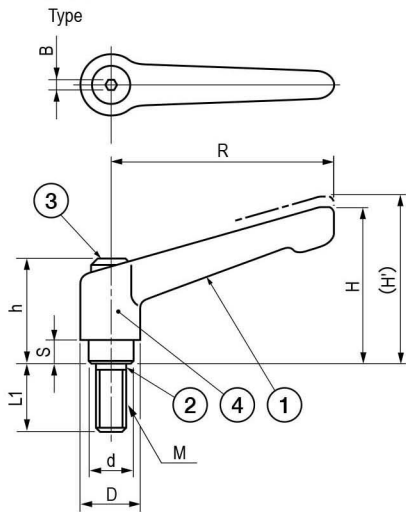

**THA-LDFタイプ**

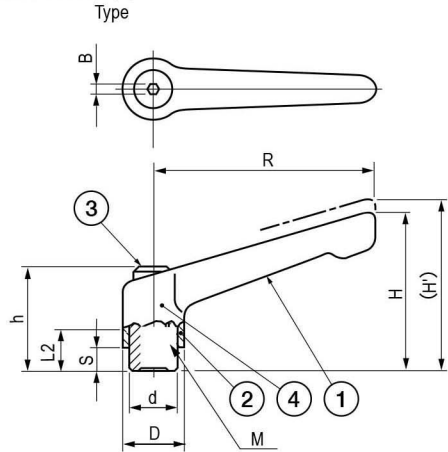

●THA-LDMタイプのご注文方法 How to Order LDM Type

LDM-5-12  
↑  
ねじ長さ  
Screw Length

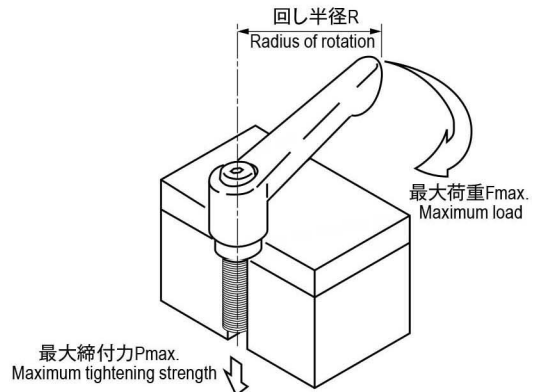

**寸法・仕様表 Size List & Specification THA-LDM (雄ねじ Male)**

型番 Model No.	L1(ネジ長さ) Screw Length	R	H	H'	h	S	D	d	M	B	歯数 Gear Number	最大荷重 FN (kgf)		最大締付力 PkN (kgf)		自重 (g) Net Weight (g)
												Max. Load FN (kgf)	Max. Tightening Strength PkN (kgf)			
THA-LDM-5-12	12	45	35	38.5	24.5	4	13	10	M5	3	18	88.3 (9)	3.92 (400)	36~38		
THA-LDM-5-16	16															
THA-LDM-5-20	20															
THA-LDM-5-25	25															
THA-LDM-5-32	32															
THA-LDM-6-12	12	45	35	38.5	24.5	4	13	10	M6	3	18	118 (12)	5.5 (560)	36~41		
THA-LDM-6-16	16															
THA-LDM-6-20	20															
THA-LDM-6-25	25															
THA-LDM-6-32	32															
THA-LDM-6-40	40	63	45	49	31	6.5	17.5	13.5	M8	4	24	180 (18.3)	10 (1020)	83~98		
THA-LDM-8-16	16															
THA-LDM-8-20	20															
THA-LDM-8-25	25															
THA-LDM-8-32	32															
THA-LDM-8-40	40	78	55	59	36	8	21	16	M10	4	26	294 (30)	15.9 (1620)	139~159		
THA-LDM-10-20	20															
THA-LDM-10-25	25															
THA-LDM-10-32	32															
THA-LDM-10-40	40															
THA-LDM-10-50	50	92	65	69	43	11	24	19	M12	5	28	432 (44)	23.1 (2350)	212~250		
THA-LDM-10-63	63															
THA-LDM-12-25	25															
THA-LDM-12-32	32															
THA-LDM-12-40	40															
THA-LDM-12-50	50	108	76	81	50.5	12	30	23	M16	5	30	903 (92)	43.2 (4400)	365~429		
THA-LDM-12-63	63															
THA-LDM-12-80	80															
THA-LDM-16-32	32															
THA-LDM-16-40	40															
THA-LDM-16-50	50	108	76	81	50.5	12	30	23	M16	5	30	903 (92)	43.2 (4400)	365~429		
THA-LDM-16-63	63															
THA-LDM-16-80	80															

**寸法・仕様表 Size List & Specification THA-LDF (雌ねじ Female)**

型番 Model No.	L2(ネジ長さ) Screw Length	R	H	H'	h	S	D	d	M	B	歯数 Gear Number	最大荷重 FN (kgf)		最大締付力 PkN (kgf)		自重 (g) Net Weight (g)
												Max. Load FN (kgf)	Max. Tightening Strength PkN (kgf)			
THA-LDF-5	8	45	35	38.5	24.5	4	13	10	M5	3	18	88.3 (9)	3.92 (400)	35		
THA-LDF-6									M6						33	
THA-LDF-8	10	63	45	49	31	6.5	17.5	13.5	M8	4	24	177 (18)	10 (1020)	74		
THA-LDF-10	14								M10						26	294 (30)
THA-LDF-12	17	92	65	69	43	11	24	19	M12	5	28	432 (44)	23.1 (2350)	178		
THA-LDF-16	23								M16						30	903 (92)