

No. 10

Capacity: 1/8" through 1" O.D.

No. 15

Capacity: 3/16" through 1 1/8" O.D.

No. 20

Capacity: 5/8" through 2 1/8" O.D.

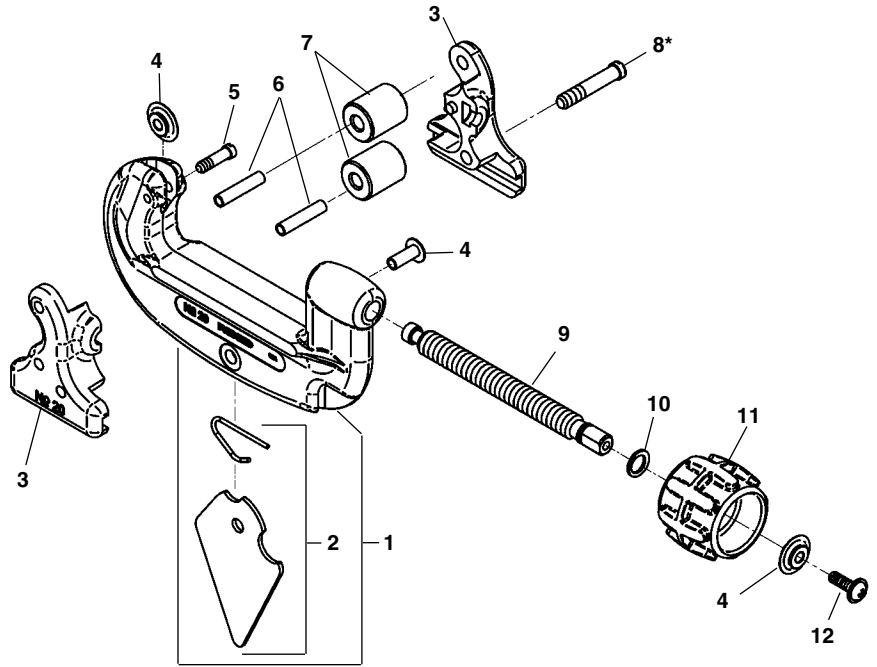

**NOTE: Order parts by Catalog Number only.
DO NOT order by Reference Number.**

Ref. No.	Description	10	15	20
		1/8"-1"	3/16"-1 1/8"	5/8"-2 1/8"
1	Frame Assembly	Catalog No. 34605	Catalog No. 34600	Catalog No. 33575
2	Reamer Blade, Spring & Pin	34330	34335	34340
3	Roll Housing	33760	34610	33580
4	Cutter Wheel (Thin)	33160	33160	33160
	Cutter Wheel (Heavy-Duty)	33165	33165	33165
5	Wheel Screw	34325	34325	34345
6	Roll Pin	34860	*	*
7	Roll	34830	34805	34825
8*	Roll Housing Screw	34300	34615	34620
9	Feed Screw	11308	11323	11313
10	Retaining Ring	11298	11303	11303
11	Knob w/Screw	33177	33182	33182
12	Screw	61097	61097	61097

*Three Roll Housing Screws (Ref. No. 8) used in place of Roll Pins.

No. 30

Capacity: 1" through 3" O.D.

Ref. No.	Catalog No.	Description
1	33375	Frame Assembly
2	34360	Wheel Screw
3	34420	Stop Screw
4	33932	Roll Pin
5	34365	Screw Handle
6	33520	Roll Housing
7	34370	Roll </td
8	33170	Cutter Wheel (Thin)
	33175	Cutter Wheel (Heavy-Duty)

