

**Hinged Pipe Cutter: No. 424CI/DI, 424S
No. 466C, 466S, 466HWS
No. 468C, 468S, 468HWS
No. 472C, 472S, & 472HWS**

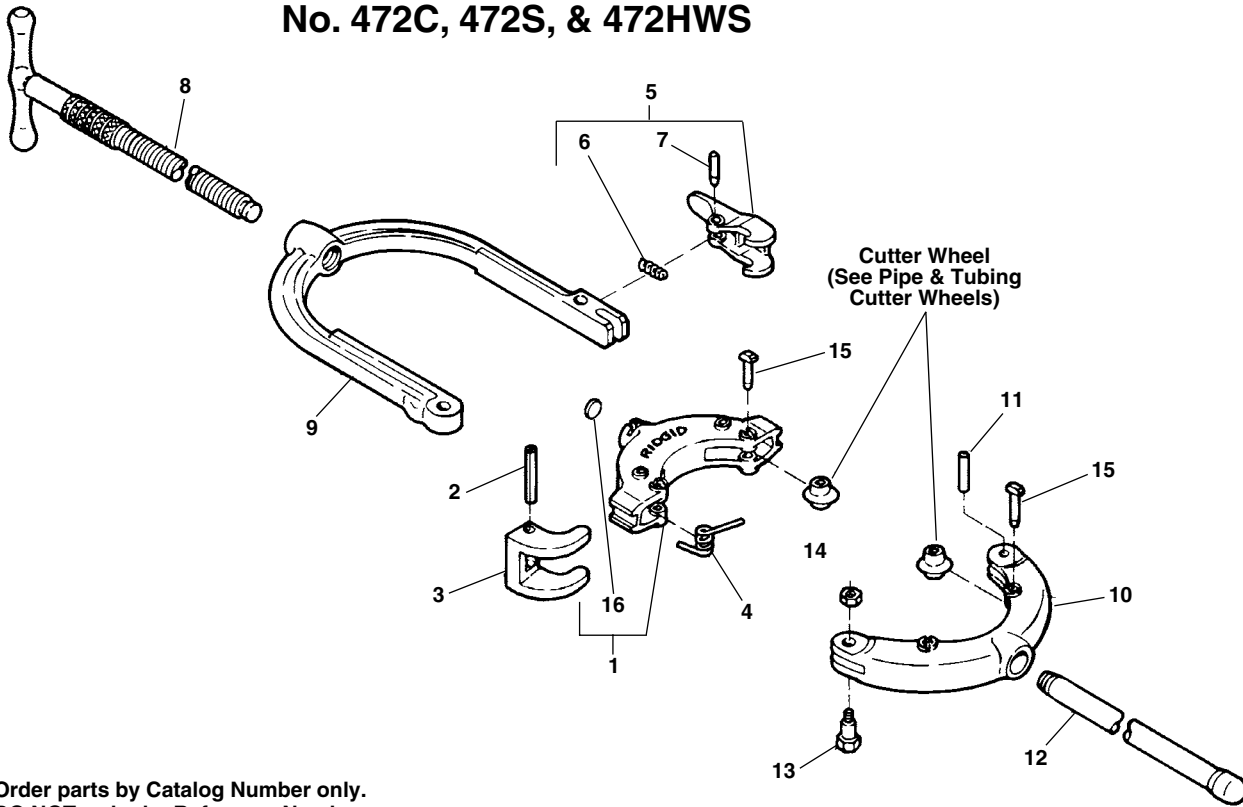

NOTE: Order parts by Catalog Number only.
DO NOT order by Reference Number.

	424 2"-4"	466 4"-6"	468 6"-8"	472 8"-12"
Ref. No.	Catalog No.	Catalog No.	Catalog No.	Catalog No.
1 Slide w/Wear Plug	75837	74690	74705	74715
2 Slide Pin (2)	83110	83110	83110	83110
3 Guide (2)	75852	83105	83105	83105
4 Guide Spring (2)	75857	83115	83115	83115
5 Latch Assembly	75887	74695	74695	74695
6 Latch Spring	83130	83130	83130	83130
7 Latch Pin	75867	50307	50307	50307
8 Handle and Screw	75847	83100	83100	83100

	424 2"-4"	466 4"-6"	468 6"-8"	472 8"-12"
Ref. No.	Catalog No.	Catalog No.	Catalog No.	Catalog No.
9 Upper Yoke	75827	83090	83155	83175
10 Lower Yoke	75832	83095	83160	83180
11 Lower Yoke Pin	83125	34375	34375	34375
12 Handle	—	38585	38585	38585
13 Hinge Bolt	83120	83120	83120	83120
14 Stop Nut	79985	79985	79985	79985
15 Wheel Pin (4)	75862	34790	34790	34790
16 Wear Plug	75872	83135	83135	83135

**No. 1-A
No. 2-A
No. 202**

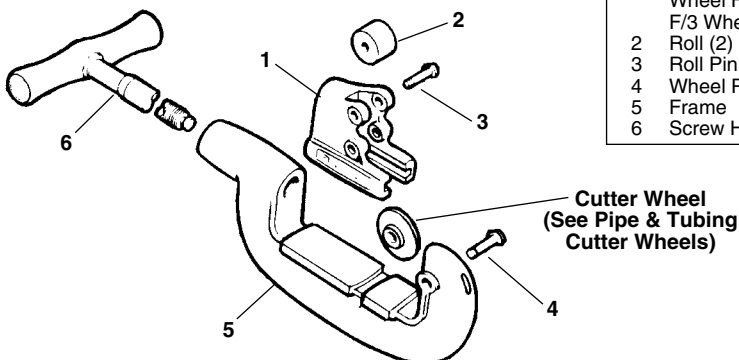

	1-A 1/8"-1 1/4"	2-A 1/8"-2"	202 1/8"-2"
Ref. No.	Catalog No.	Catalog No.	Catalog No.
1 Roll Housing	33765	33765	33400
Wheel Housing	34885	34885	—
F/3 Wheel	—	—	—
2 Roll (2)	34775	34775	34305
3 Roll Pin (2)	34780	34780	34310
4 Wheel Pin	34780	34780	34780
5 Frame	33310	33305	33305
6 Screw Handle	33510	33505	33505