

除電電極接続ケーブル用コネクタ

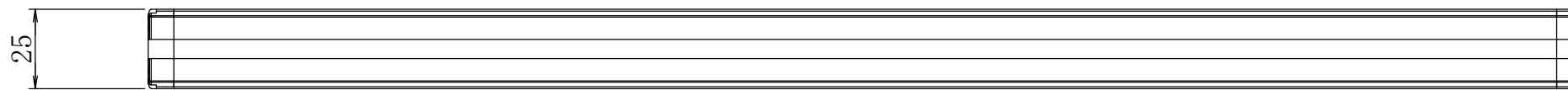

ACアダプタ接続口

イオンバランス微調整ボリューム

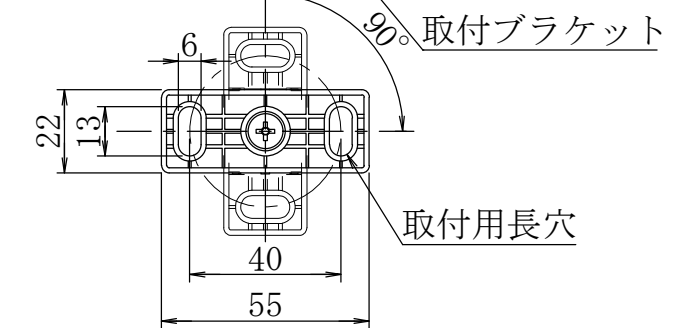
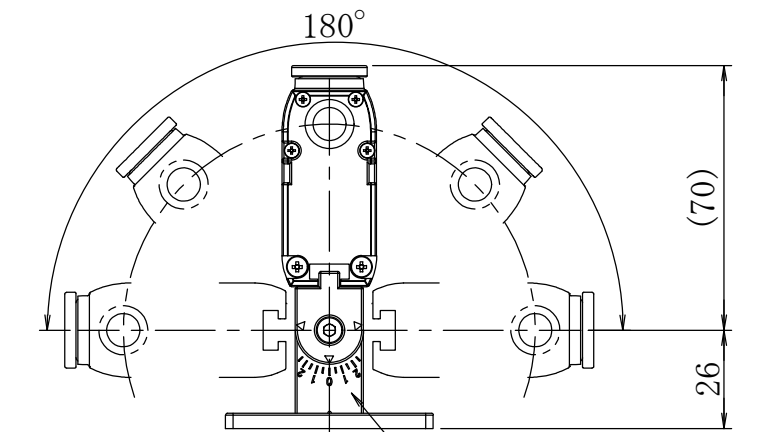
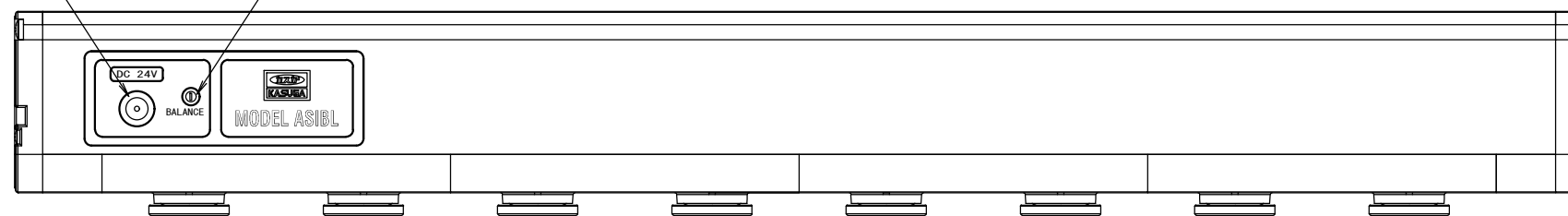

ブラケット取付時

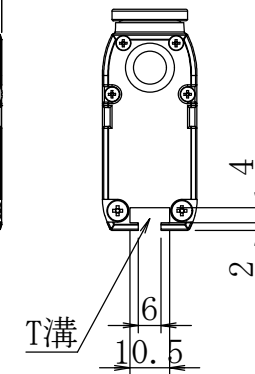

寸法表 [UNIT: mm]

長有効	全長	針々間	ノズル数
400	450	350	8
500	550	450	10
600	650	550	12
700	750	650	14
800	850	750	16
900	950	850	18
1000	1050	950	20
1100	1150	1050	22
1200	1250	1150	24
1300	1350	1250	26
1400	1450	1350	28
1500	1550	1450	30
1600	1650	1550	32
1700	1750	1650	34
1800	1850	1750	36
1900	1950	1850	38
2000	2050	1950	40
2100	2150	2050	42
2200	2250	2150	44
2300	2350	2250	46
2400	2450	2350	48
2500	2550	2450	50
2600	2650	2550	52
2700	2750	2650	54
2800	2850	2750	56
2900	2950	2850	58
3000	3050	2950	60

Specifications and design is subject to change without notice.

SCALE
1/2
[Unit:mm]
DATE
'20, 3, 1

KASUGA DENKI, INC.

Title
除電電極 ASIBL

DRAW No. 8559NA00040_H