

床固定金具、連結金具各4個、M4トラスネジ8個付属
抽斗耐荷重30Kg

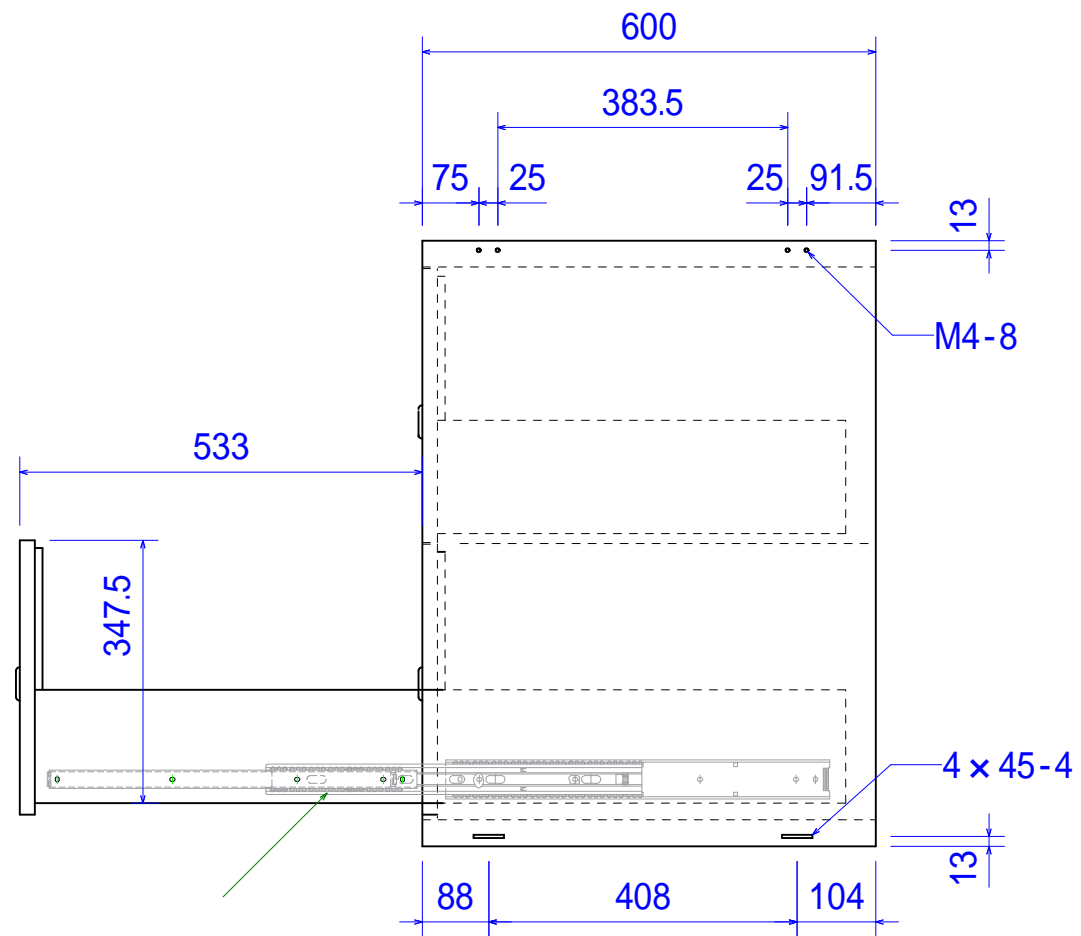
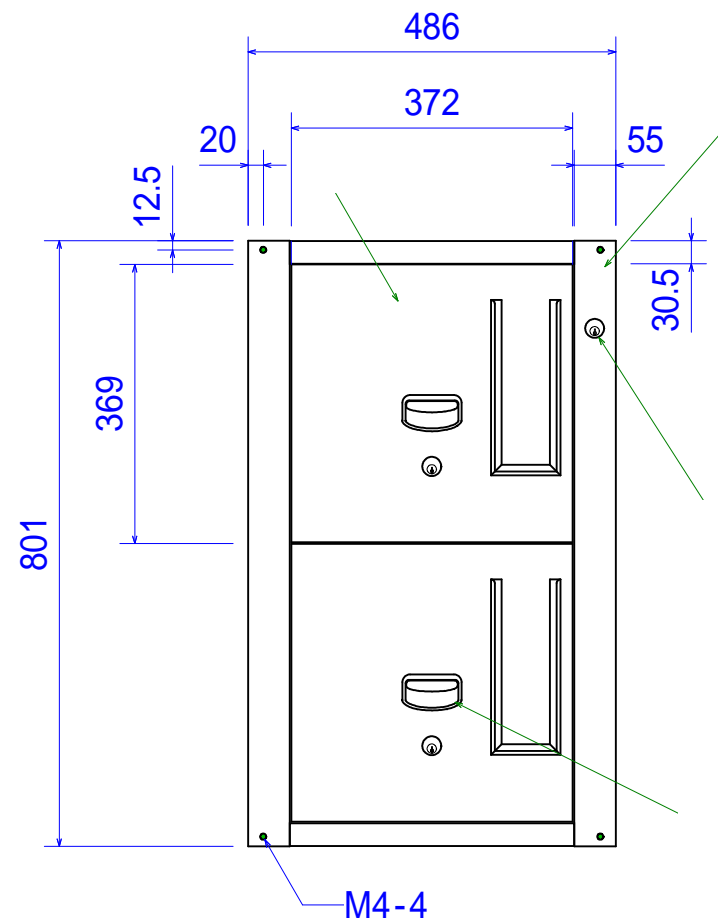

訂正	.	.					名称 GU-3E1W	No.				
	.	.							担当 設計 製図 検図	寸法 縮尺	年月日 図面	図面番号
	.	.							股			